



**Pre Insulated Tube**



**KWANG SHIN I.S.T CO., LTD.**



## Machinery & Test Equipment

### Machinery

1. Welding M/C (3 ea)
2. Cold Drawing M/C (5 ea)
3. Swejinggi M/C (3 ea)
4. Compressor (2 ea)
5. Forklift (1 ea)
6. Crain (4 ea)
7. Heat Treatment Furnace (5 ea)
8. Marking M/C (2 ea)
9. Eddy Current M/C (1 ea)
10. Wrapping M/C (1 ea)
11. Insulated Forming M/C (2 ea)
12. Extruder M/C (1 ea)
13. Bench Lathe (2 ea)
14. Coil Straight M/C (1 ea)
15. Straight M/C (1 ea)
16. Grinding M/C (1 ea)
17. Hydrogen Generator M/C (1 ea)

18. Mountain Press M/C (1 ea)
19. Polishing M/C (1 ea)

### Test Equipment

1. Hardness Tester (1 ea)
2. Universal Tester (1 ea)
3. Specimen Cutter (1 ea)
4. Burst Tester (1 ea)
5. Hydraulic Tester (1 ea)

## Pre-Insulated Tube

### 1. What is Pre-Insulated Tube?

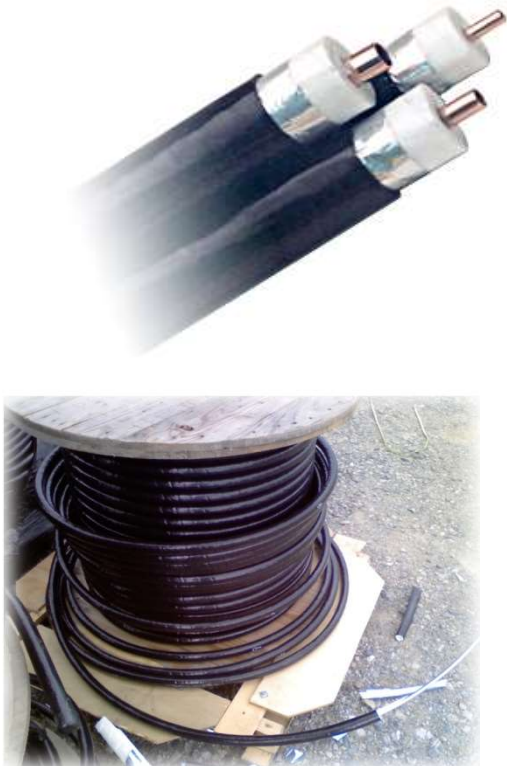

#### 1) Definition –

Pre-heated & insulated tube that does not require a separate field insulation

#### 2) Purpose –

Temperature maintenance of liquid, Frost Protection, Freeze Protection

To prevent the sudden change of temperature through the warming, and to increase the thermal efficiency by preventing the warming, cooling, transferring and freezing of steam, high temperature or low temperature fluid and gas.

#### 3) Usage –

Transmission of hook up & sample line regular drinking water, industrial steam, water pipeline

## Pre-Insulated Tube

### 2. Specification of Pre-Insulated Tube

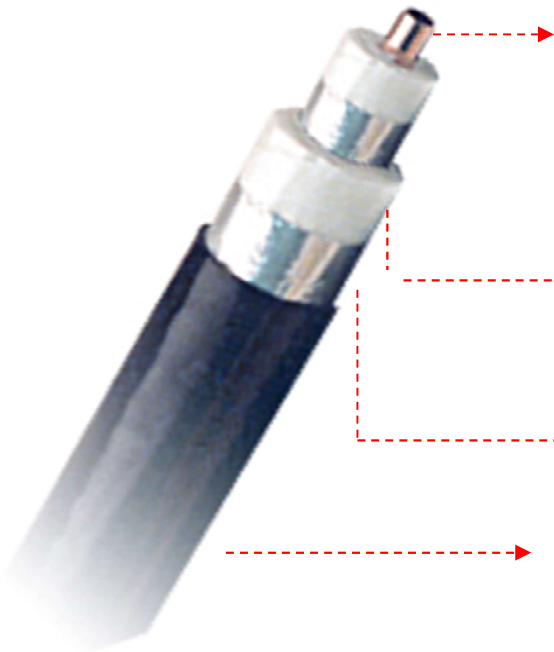

1) Process Tube

Material: SUS, Copper Teflon and etc.

Size : ¼ "to 3/4" (mm size is possible)

Thickness : \*Flexible for all product lineup

2) Insulation

Material : Non-Flammable E-Glass Fiber  
Aerogel

3) Heat Reflective Tape

4) FR-PVC Jacket

60°C outer jacket temperature when  
204°C is the maximum allowed  
temperature under UV Protection /  
Maximum Exposure 102°C Process  
Temperature

**Pre-Insulated Tube**

3. Other Products



Tube Trace ( heating Cable)



Tube Trace ( Heavy Steam)



Tube Trace ( Light Steam)



Tubing Bundle

# Pre-Insulated Tube

## 4. Product characteristics & comparison

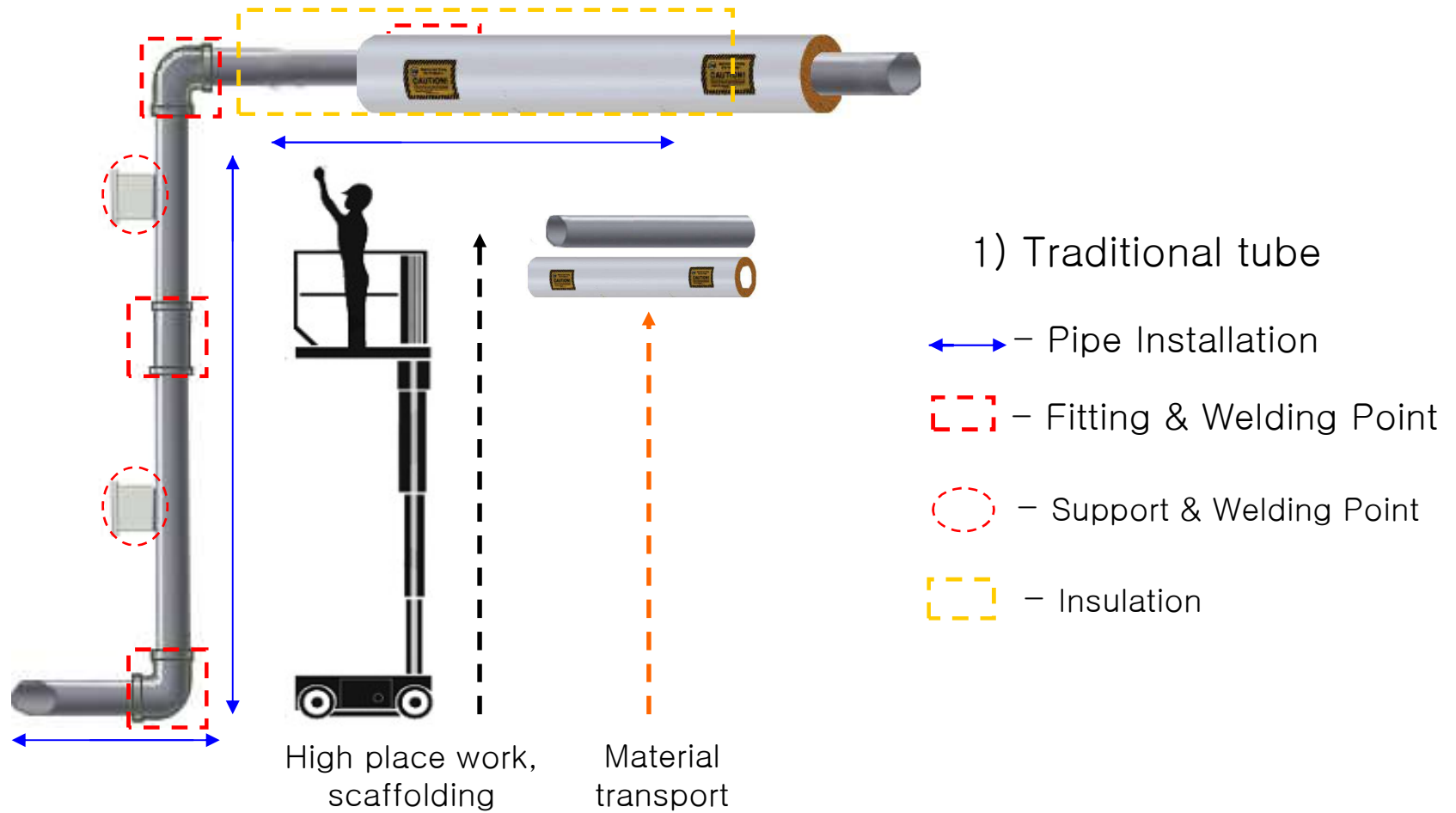

# Pre-Insulated Tube

## 4. Product characteristics & comparison

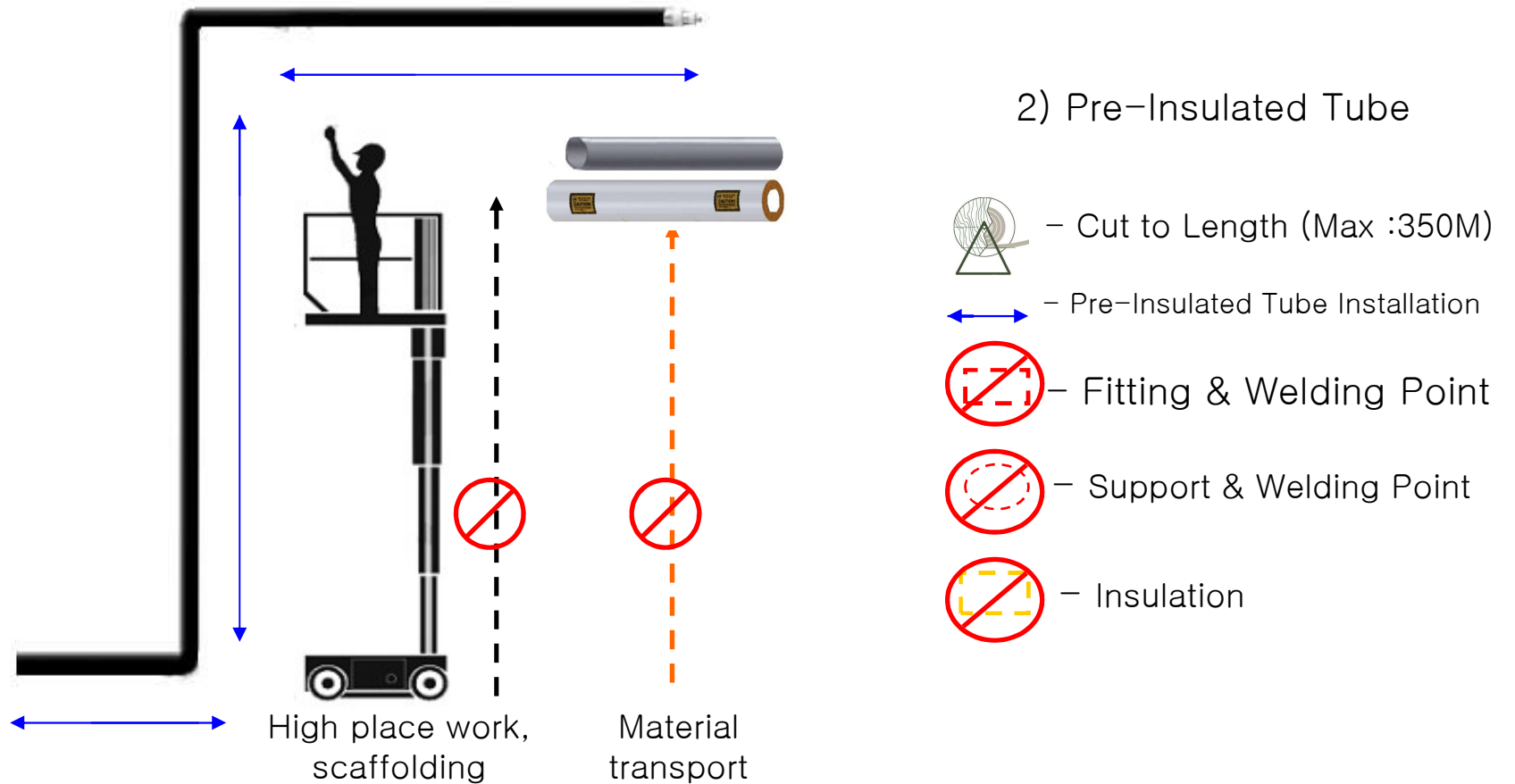



## Pre-Insulated Tube

### 6. Piping & Field Insulation vs. Pre- Insulated Tube Post installation Comparison



**Pre-Insulated Tube**



**Pre-Insulated Tube**



**Pre-Insulated Tube**



**Pre-Insulated Tube**

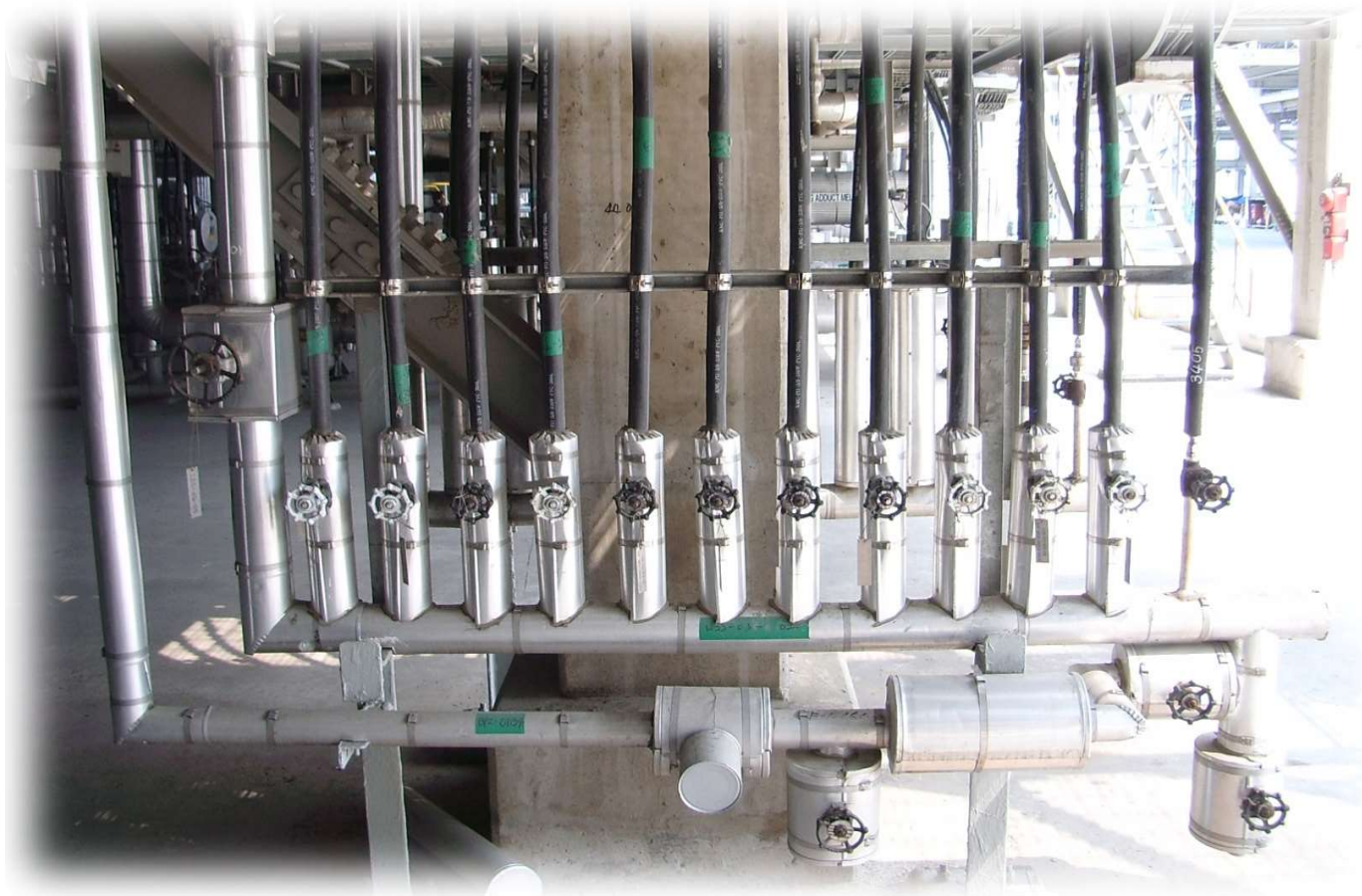

**Pre-Insulated Tube**

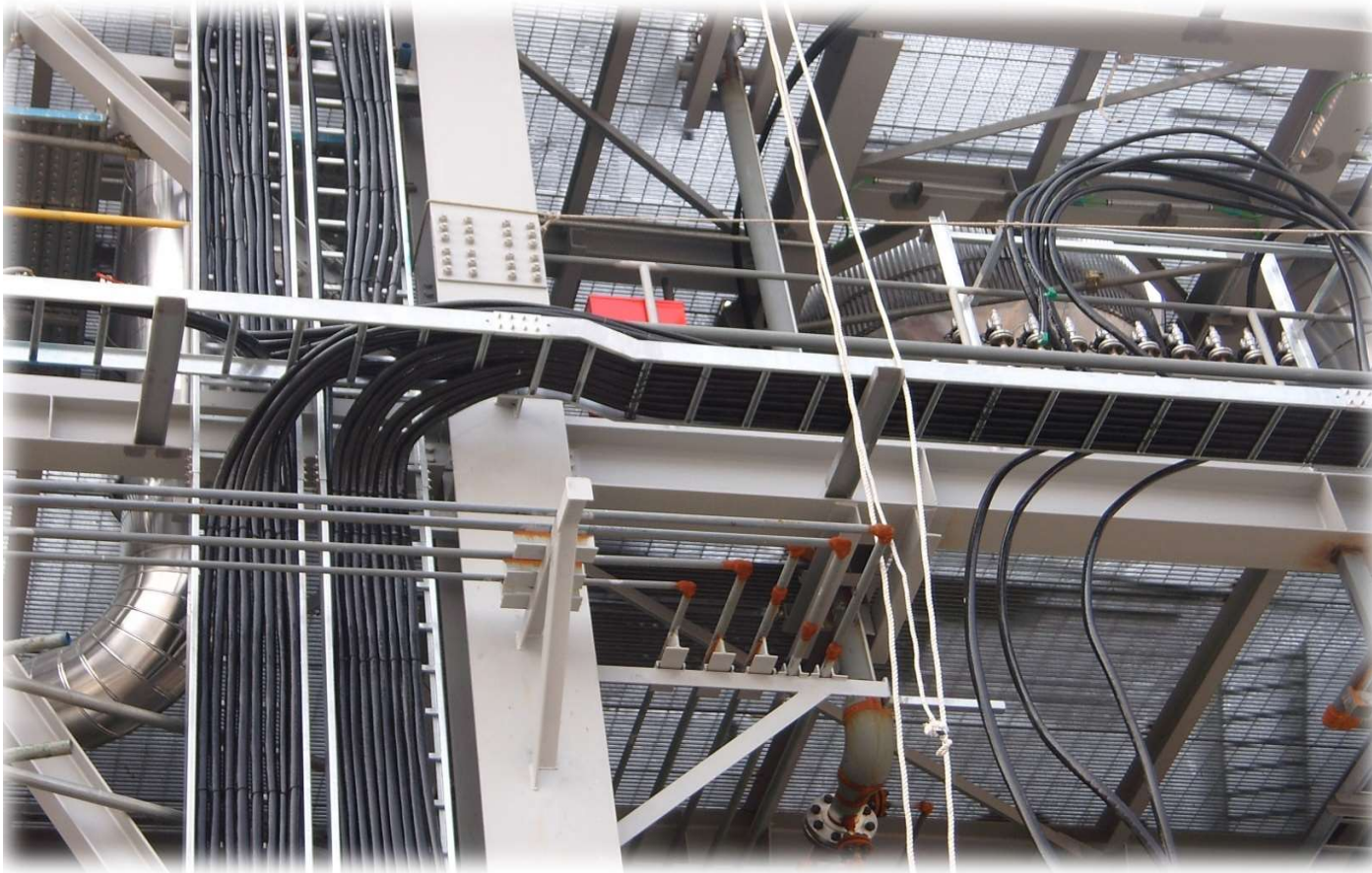

# Pre-Insulated Tube

## 7. Pre- Insulated Tube thermo keeping capability (Heat Loss)

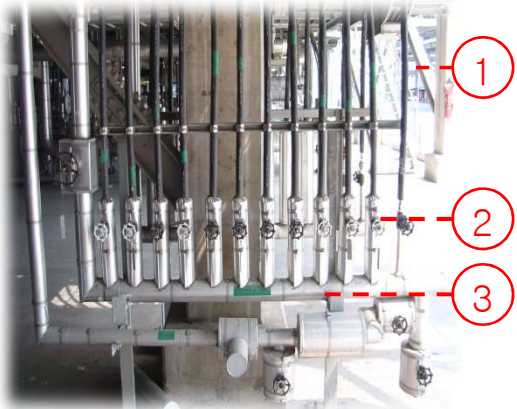

1.Pre-Insulation Tube	2. Bare Tube	3. Hitlin 25T
34 °C	153 °C	29 °C

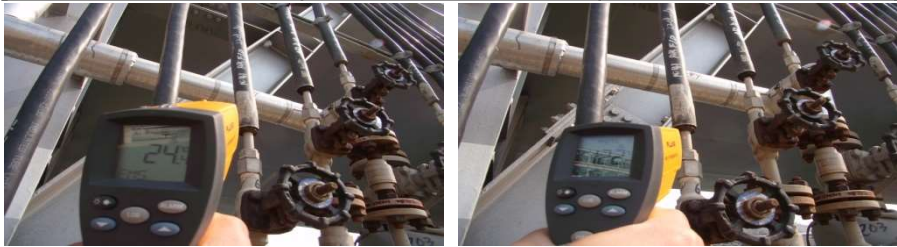
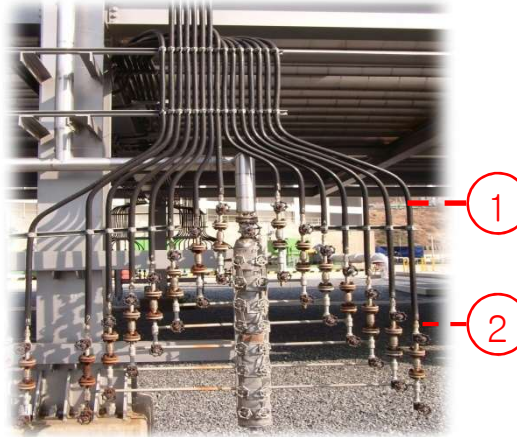



1.Pre-Insulation Tube: 24 °C	2. Bare Tube : 122 °C
---------------------------------	--------------------------

At 17°C air temperature

**Pre-Insulated Tube**

8. Pre-Insulated Tube Installation Status

User List	Project Name	Product Type
	Daesan Revamping(In use) Daesan new plant (Planned)	Pre-insulated Tube
	Yeosu Plan 1 (Replacement) HPC PJT (In use) Daesan SEG PJT (In use)	Pre-insulated Tube Tube Bundle Tube Tracer
	Ulsan BDO PJT Ulsan SK#2 KMX	Pre-insulated Tube Tube Tracer
	Yeosu HOU NO.2 PJT (In use) YeosuHOU NO.4 PJT (In use) Yeosu HOU NO.3 PJT (Planned)	Pre-insulated Tube Tube Bundle Tube Tracer
	Yeosu BPA-1 PJT (In use) Yeosu BPA-2 PJT (In use)	Pre-insulated Tube Tube Tracer
	Daesan Revamping PJT(In use)	Pre-insulated Tube



# Pre-Insulated Tube

## 9. Why Kwang Shin?

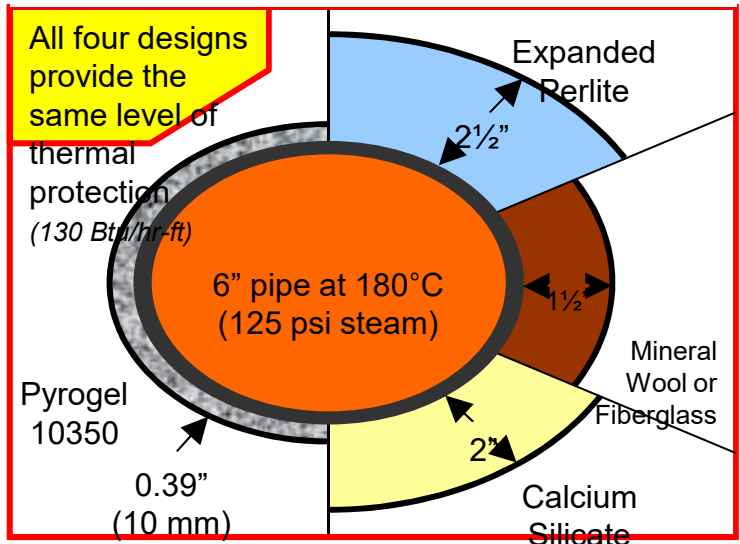

### 1) Differentiation

- 50% thickness vs. traditional tube
- 2 times thermo keeping efficiency vs. traditional tube

- Higher than 2" Pre-Insulated Pipe production
- Exclusive supply agreement with Aerogel Korea
- Autonomous manufacturing capacity

### 2) Cost saving & Quality control

- Less than 50% in price vs. imported products
- Reduced production cost & improved quality through complete "Non-stop" production line from stainless steel pipe mil to insulation process

**Pre-Insulated Tube**

10. Major Customers





# Pre-Insulated Tube

## 11-2 Certifications

Certificate of Patent

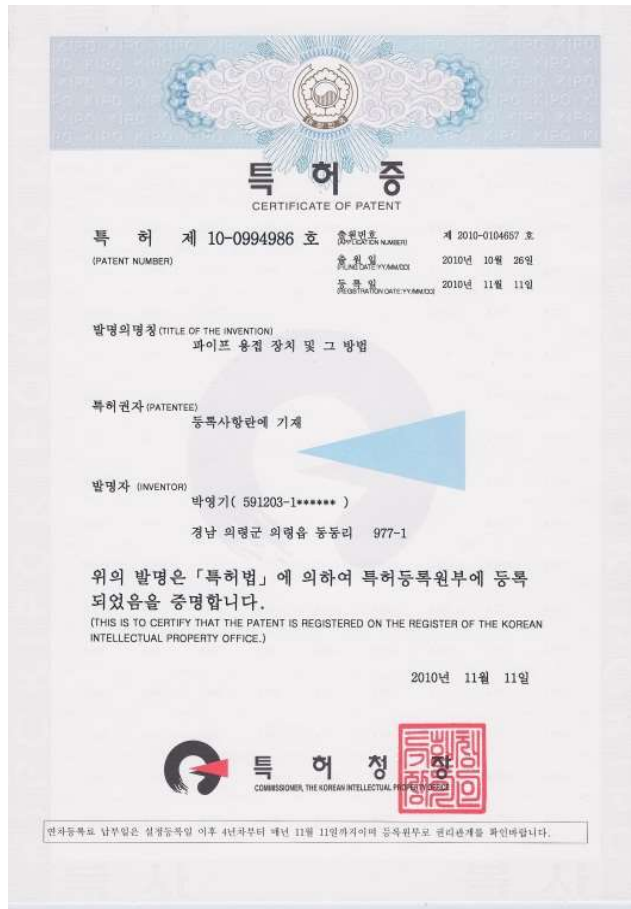

Certificate of Cooperative Company

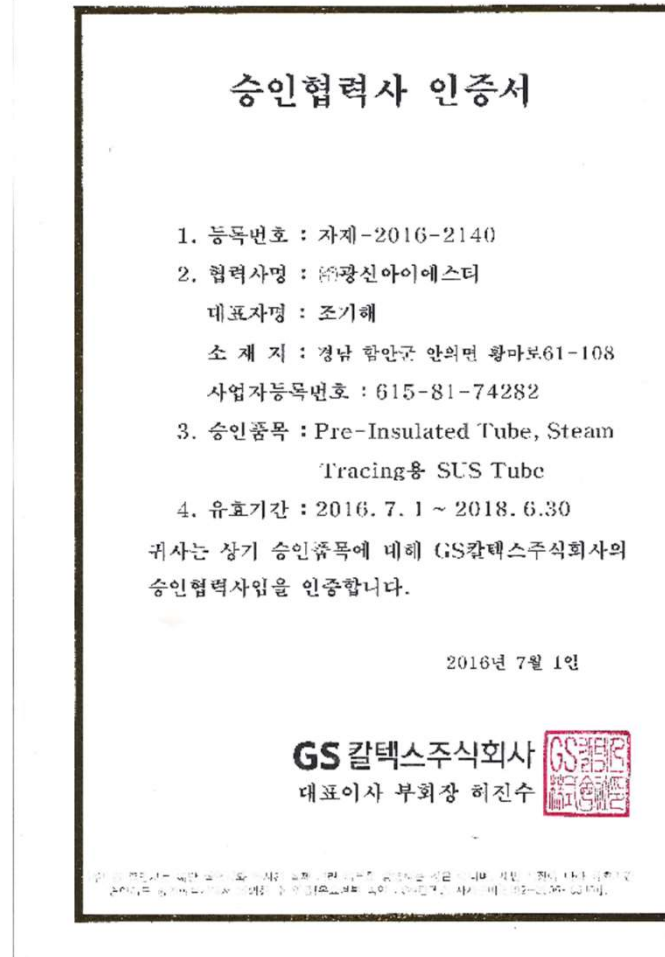

***Thank you!***